

## Delta Fresh Air Supply Fans

### VDB400GXTH-F

#### Features

- High Efficiency Brushless DC Motor
- Low Power Consumption
- Low Noise Design
- Double High Efficiency Filters (Primary filter and HEPA)
- Filtration efficiency up to 97%
- Dual Speed Control + ECO model
- Soft Start Control and Locked Protection
- RS485 Protocol, available in smart home



#### Application

Dining Room & Living Room / Meeting Room / Office

#### Application Space

< 150 m<sup>2</sup>

#### Dimensions unit: mm

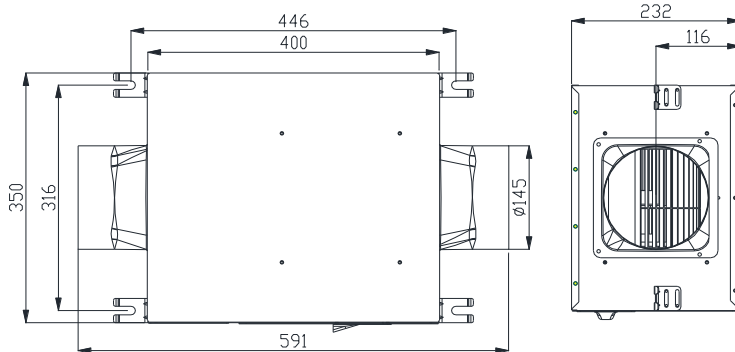

#### P&Q Curve

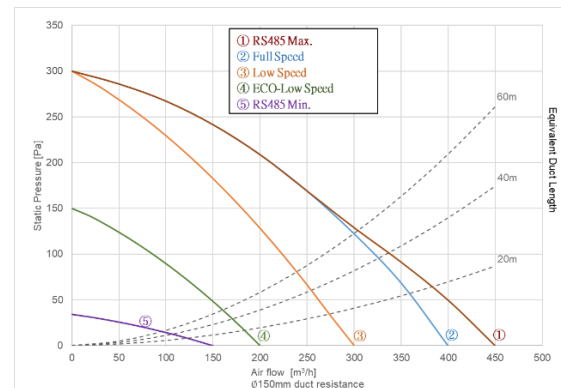

#### Specifications

Model	Install size	Weight	Power Rating	Power Consumption	Maximum Air Flow	Maximum Air pressure	Noise	PM2.5 Filtration Efficiency	Remark
PART NO.	mm	kg	VAC/Hz	Watts	m <sup>3</sup> /h	Pa	dB-A	%	---
VDB400AGXTH-F	446 X 316	10	220/50	55	400	300	32	>97	High
				25	300		28		Low
				12	200	150	23		ECO-Low
				Max.62	Max.450	Max.300	Max.34		RS485

\* Noise is measured under the 1.5 meter, product with duct in inlet and outlet.

\* Noise is measured in semi-anechoic chamber in free air, the actual installation state contain other noise which influence higher measured value.

\* The air flow is the average value with  $\pm 10\%$  tolerance.

\* Specifications are subject to change without notice.